

Inpro/Seal Presents: The Latest Addition to a Growing Family of Shaft Seals.

Strong customer demand for a long-lasting, reliable shaft seal that could be used in applications involving wet or dry particulates, powders and slurries is what led Inpro/Seal to roll out its first shaft seal product, the Air Mizer- PS, almost 10 years ago. Based on extensive R&D, the Air Mizer was a modification of the company's highly successful bearing isolator, which was adapted to incorporate an air purge containment system. In this innovative design, a solid wall of air functions as a barrier for contamination to retain product in vessels without contact or wear. Over the years, this family of innovative products has continued to grow, first with the introduction in 2007 of the company's Smooth Bore Air Mizer and in September 2008 with the launch of the Inpro/Seal Water Mizer. This latest addition to the product line incorporates the same features as the previously introduced Air Mizers, but with one big difference. Instead of an air purge containment system, it uses water to attain the seal.

- A 1/2" waterline connection attaches to a regulator to control the water pressure.
- A drain is located on the back side.
- The shaft "floats" on a water barrier directly on the shaft.
- Without any moving parts, there is zero contact, zero wear and zero frictional drag.

Inpro/Seal Shaft Seals are custom-engineered to suit individual applications and are easy to install. Split designs allow for installation directly on the shaft without the removal of couplings and end plates. According to Inpro/Seal, once these products are installed, problems associated with shaft deflection, radial run-out, axial displacement and misalignment that have caused previous sealing methods to fail become a thing of the past.

WATER MIZER

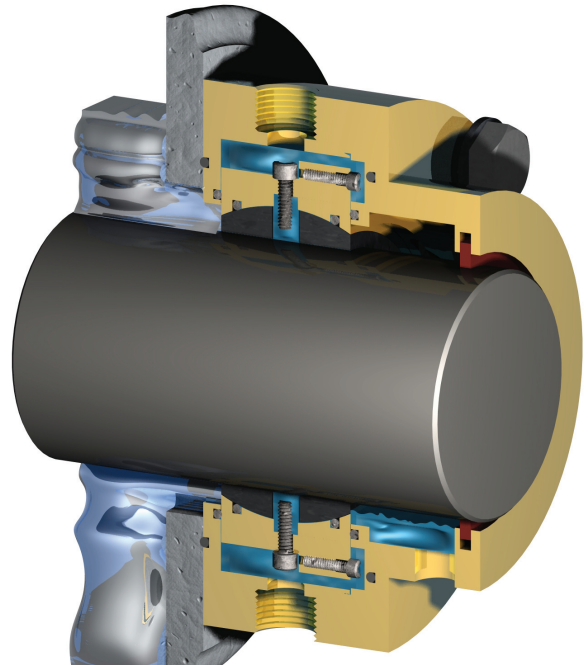

AIR MIZER



Typical applications include: screw conveyors, mixers, blenders, rotary valves, feeders, gates, clinker grinders, bucket elevators, diverters, scales, bagging machines, dust collectors, discharges, classifiers, screens, extruders, separators, shredders, sifters, gate valves, metal detectors, pulverizers, crushers, coolers, aerators, transfer pumps, agitators, fillers and similar wet and dry powder and slurry processing equipment.

**For additional information visit
www.inpro-seal.com or contact 800-447-0524.**